

Ref. 1343 (KD-B190)

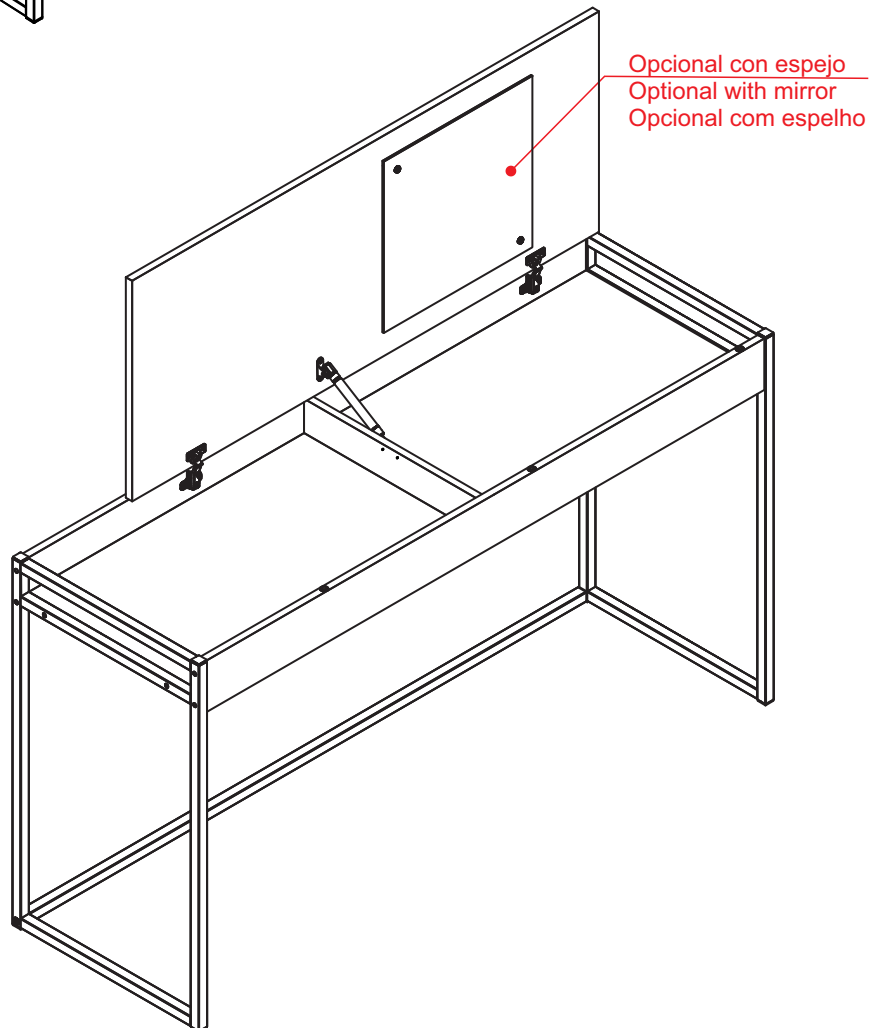
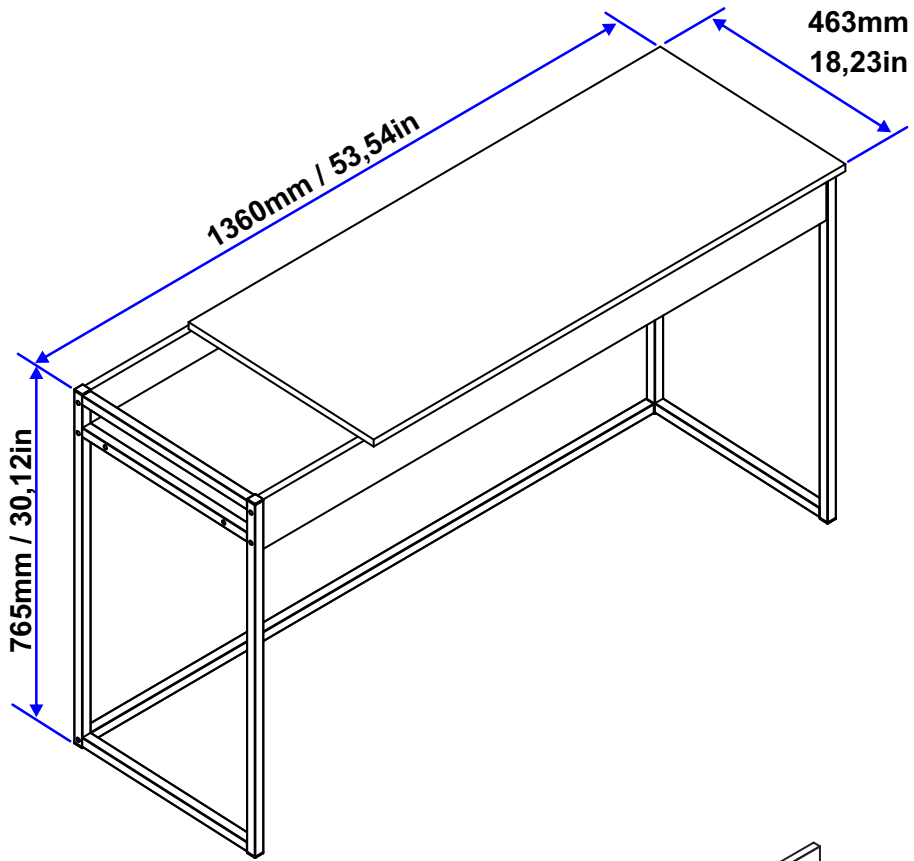

Consejos de Conservación

- No debe utilizarse en la limpieza, abrasivos como lana de acero, alcohol, vinagre, limón, o productos corrosivos que puedan rayar o quitar la película protectora en los muebles.
- Cuando la limpieza de muebles en general, napa y formica, deben utilizarse un paño ligeramente humedecido y jabón suave.
- Para mover el mueble, es importante que este se eleve desde el suelo, debido a que el arrastre puede causar daño estructural.
- No deje el mueble en exposición a la intemperie.

Conservation Tips

- Do not use abrasive products to clean such as steel wool, alcohol, vinegar, lemon, scouring powder, or corrosive products which can scratch or peel off the protective film of the furniture.
- The best way to clean your furniture is to use a slightly moistened cloth with a mild soap.
- To move the furniture assembled, it is important that it is lifted off the ground, because the drag it can cause structural damage.
- Do not leave your furniture in weather exposure.

Dicas de Conservação

- Não utilizar na limpeza produtos abrasivos tais como: palha de aço, álcool, vinagre, limão, saponáceo, ou produtos corrosivos que possam riscar ou descolar a película protetora dos móveis.
- Na limpeza de móveis em geral, napa e fórmicas, deve ser utilizado um pano levemente umedecido e sabão neutro.
- Para a movimentação do móvel, é importante que este seja levantado do chão, pois ao arrastá-lo pode causar avarias estruturais.
- Não deixe o móvel em exposição a intempéries.

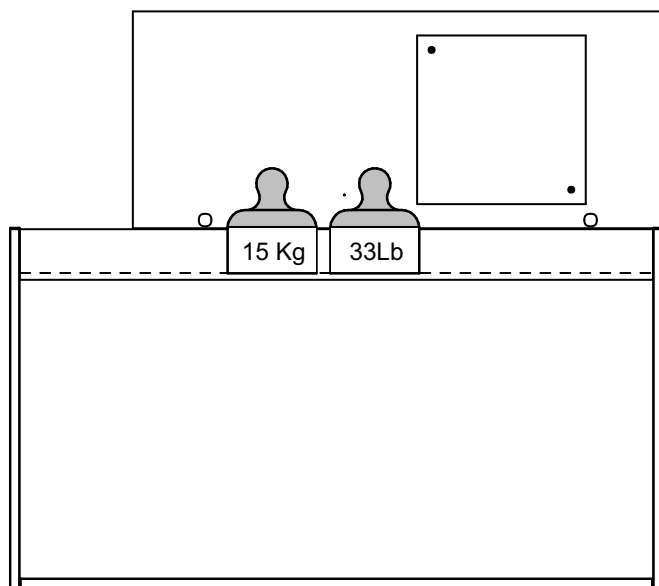

Peso soportado

Por favor, preste atención a los pesos máximos admitidos por cada compartimento del producto. Tenga cuidado de no exceder estos pesos, con el fin de garantizar la calidad y durabilidad del producto.

Es importante recordar que los pesos muestran en caso de ser distribuida en toda el área de la plataforma.

Supported Weight

Please pay attention to the maximum weights supported by each compartment product. Be careful not to exceed these weights, in order to ensure the quality and durability of the product. It is important to remember also that the weights shown should be distributed throughout the area of the shelf.

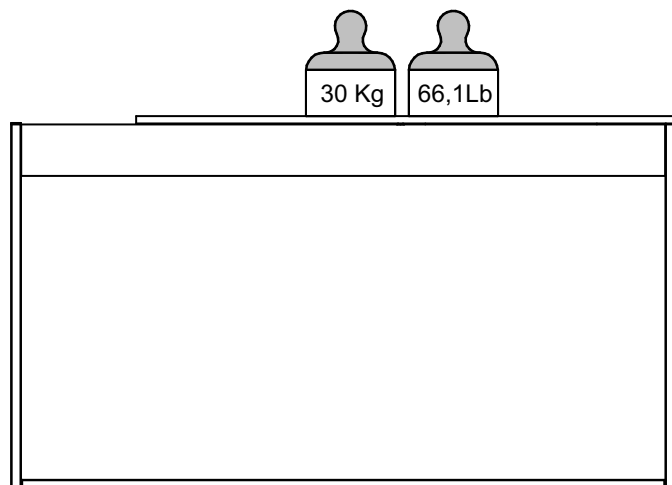

Peso Suportado





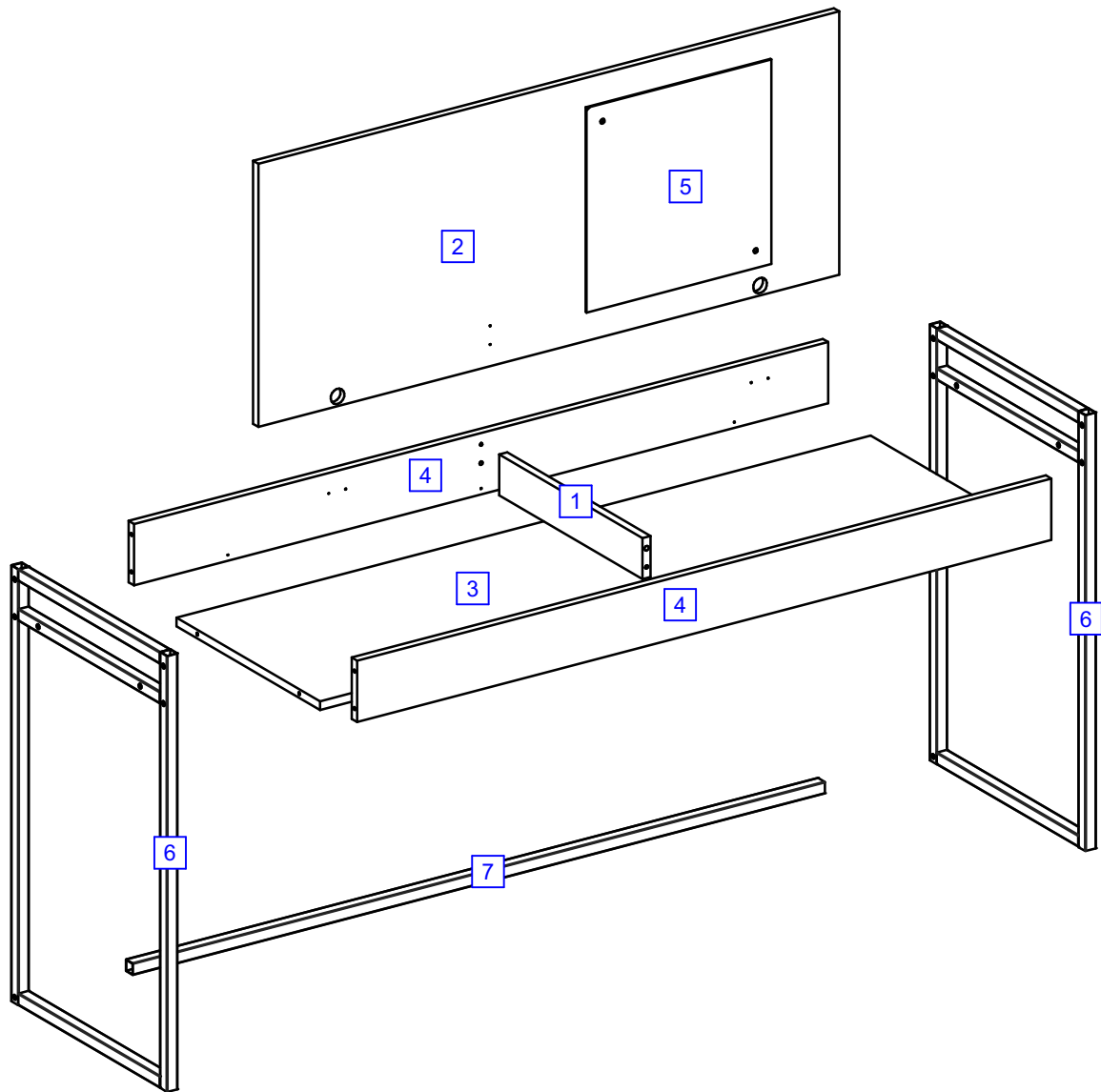



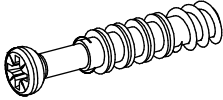
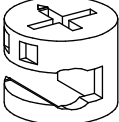

Ao lado são demonstrados os pesos máximos suportados por cada compartimento do produto. Cuide para não exceder esses pesos, afim de garantir a qualidade e a durabilidade do mesmo. É importante lembrar também, que os pesos mostrados devem ser DISTRIBUÍDOS ao longo de toda a área da peça.

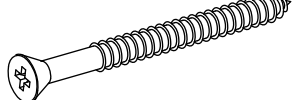
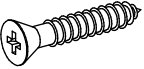
LISTA DE PIEZAS / LIST OF PARTS / RELAÇÃO DE PEÇAS

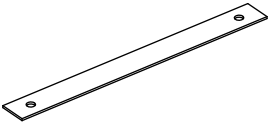
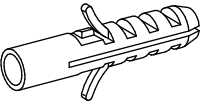

#	Qt.	Español	English	Português	Dimensões
1	1	División	Division	Divisão	405x70x15mm/15,94x2,76x0,59in
2	1	Puerta	Door	Porta	1100x450x15mm/43,31x17,72x0,59in
3	1	Repisa	Shelf	Prateleira	1314x405x15mm/51,73x15,94x0,59in
4	2	Travesaño	Crosspiece	Travessa	1314x105x15mm/51,73x4,13x0,59in
5	1	Espejo	Mirror	Espelho	350x350x3mm/13,78x13,78x0,12in
6	2	Lateral Metálica Derecha/Izquierda	Right/Left Metallic Side	Lateral Metálica Direita/Esquerda	745x440x20mm/29,33x17,32x0,79in
7	1	Tubo Inferior	Lower Tube	Tubo Inferior	1310x20x20mm/51,57x0,79x0,79in

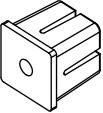
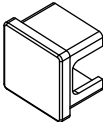
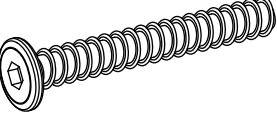
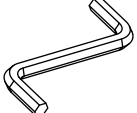
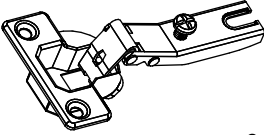
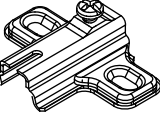
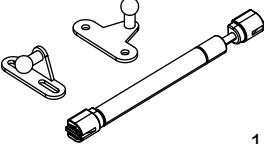
Accesorios / Accessories / Acessórios

A  2 un.	B  Ø15mm/0,59in 2 un.	C  Ø6 x 30mm/0,24 x 1,18in 2 un.	D  Ø4 x 50mm/0,16 x 1,97in 4 un.
E  Ø4,0 x 25mm/0,16 x 0,98in 2 un.	F  6 un.	G  6 un.	H  2 un.
I  Ø6mm/0,24in 4 un.	J  6 un.	K  2 un.	L  Ø3,5 x 14mm/0,14 x 0,55in 24 un.
M  2 un.	N  8 un.	O  Ø7 x 50mm/0,28 x 1,97in 14 un.	P  1 un.
Q  2 un.	R  2 un.	S  1 un.	T  3 un.

Regla para Medir Tornillos
 Rule to Measure Bolts
 Régua para Medir Parafusos

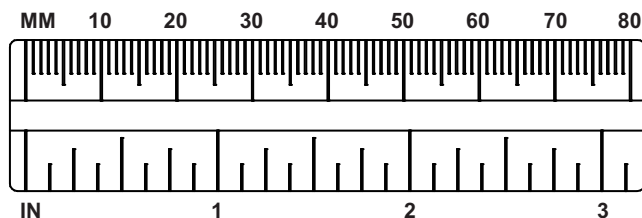

Taladro Ø6mm/0,24in
 Drill Ø6mm/0,24in
 Broca Ø6mm/0,24in



Herramientas
 Tools
 Ferramentas

90 min.



Personas Necesarias
 People Required
 Pessoas Necessárias



4

Pre montaje
Pre assembly
Pré Montagem

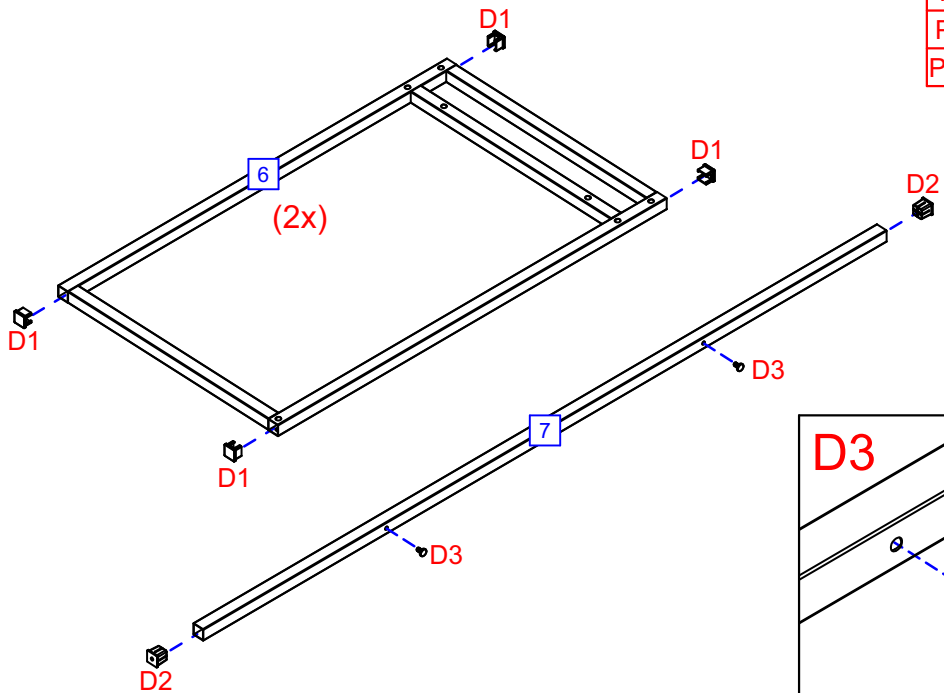
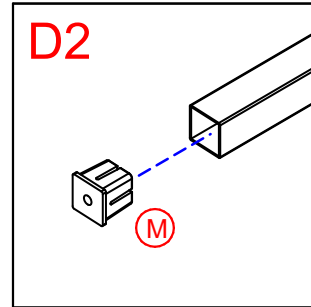
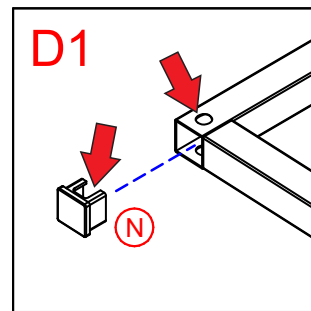
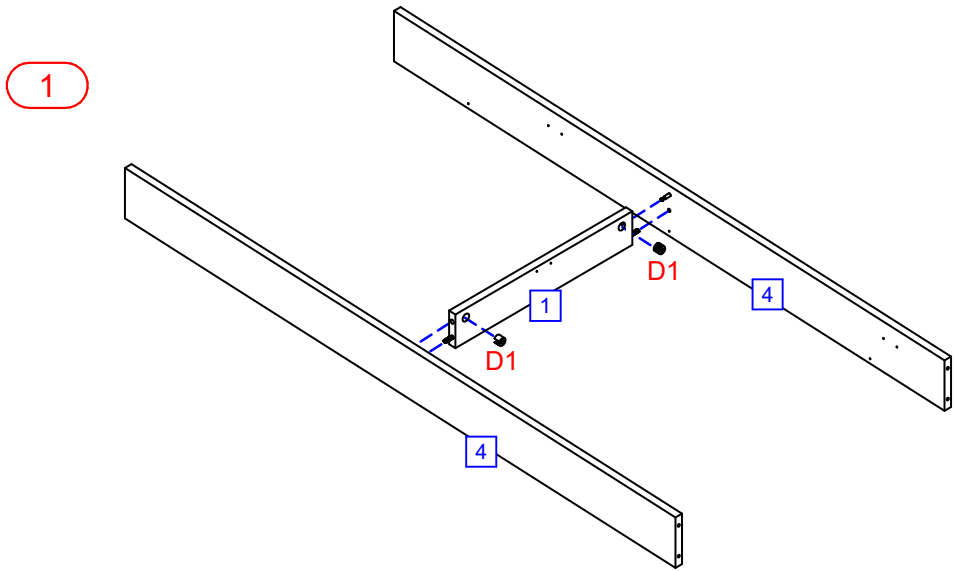
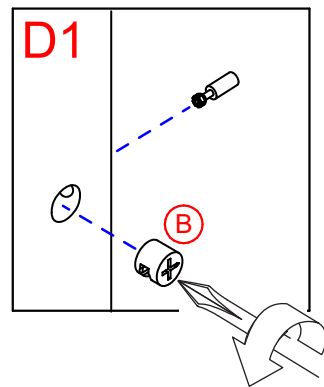
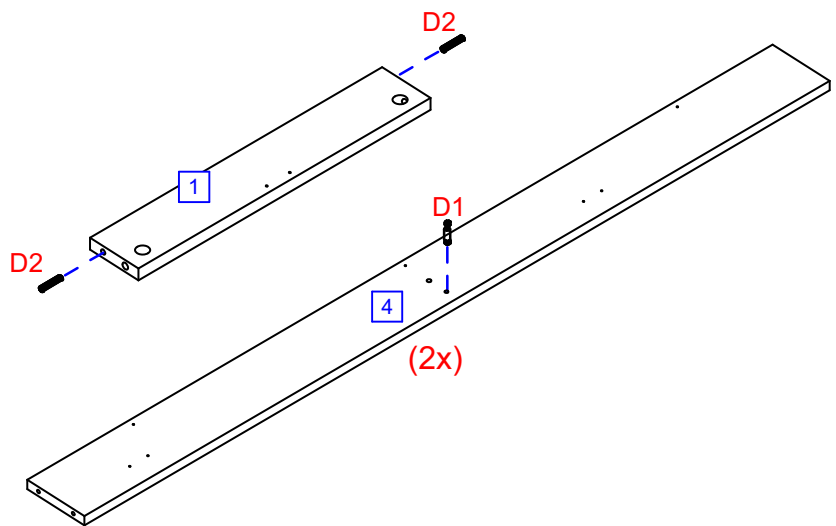
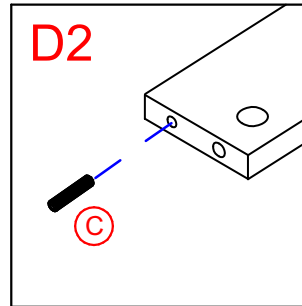
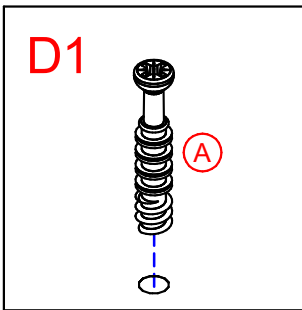

Pre montaje
Pre assembly
Pré Montagem

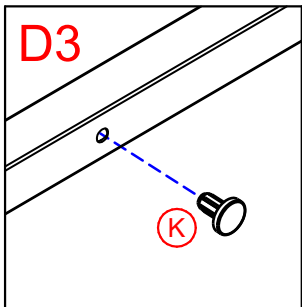

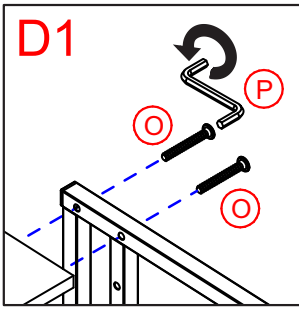

Módulo armado en la página 5
 Module assembled on page 5
 Módulo montado na página 5

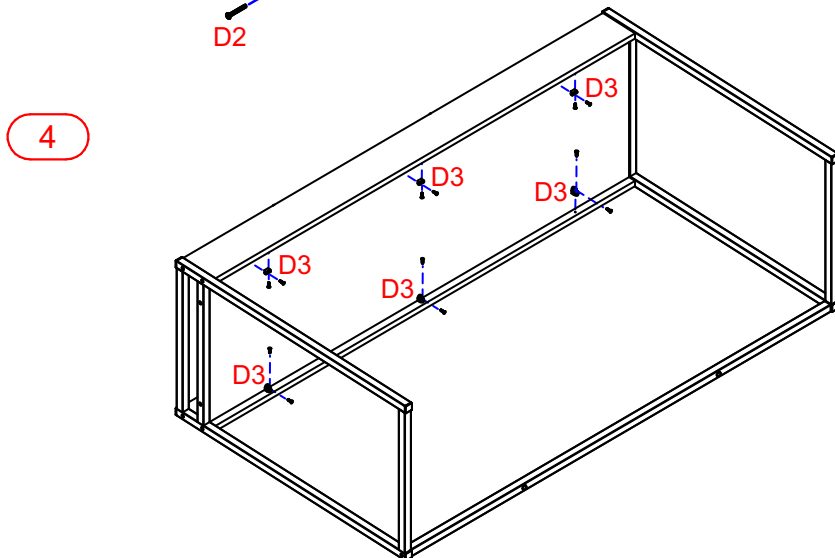
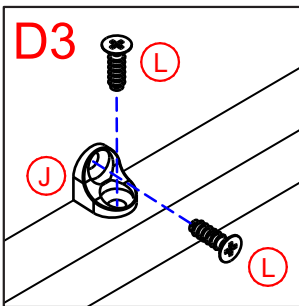
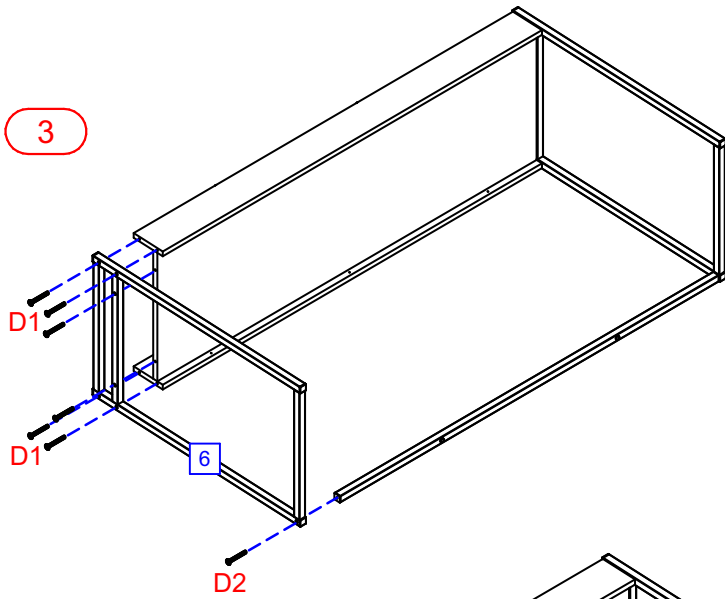
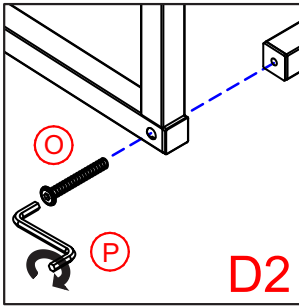
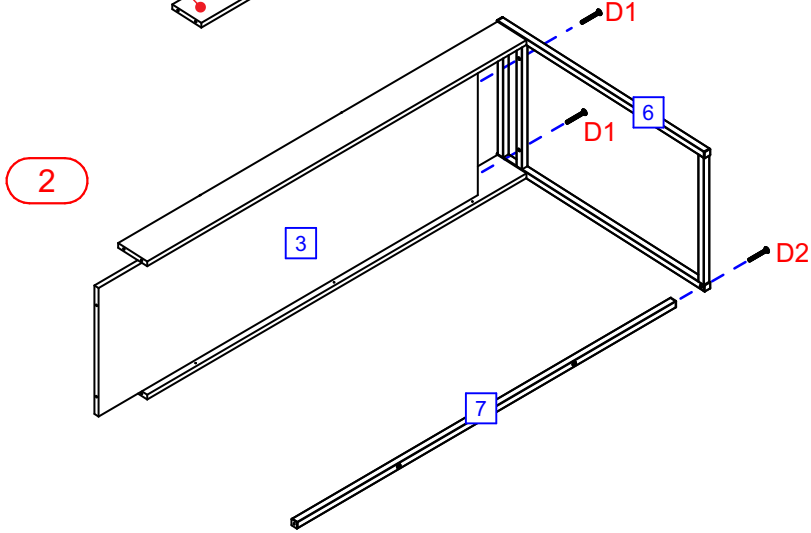
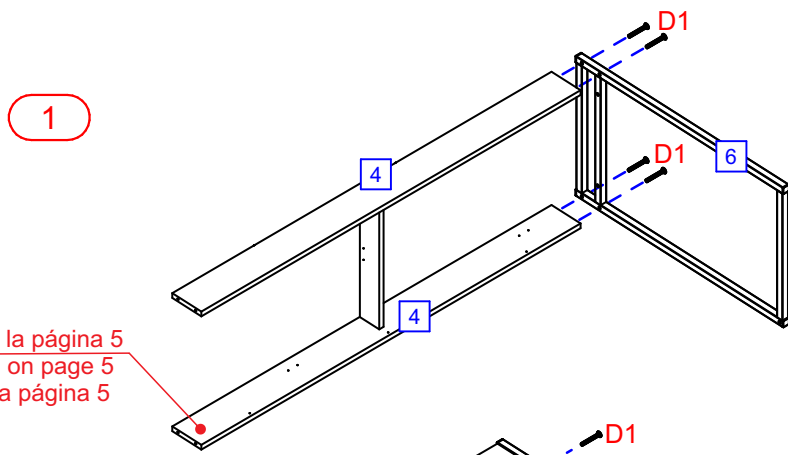

Montaje en pared - Opción 1
Wall Mounting - Option 1
Monatgem na parede - Opção 1



Es obligatorio fijar este producto a la pared, como se muestra en este paso. Por favor, consulte los detalles en la última página. / It is obligatory to fix this product to the wall, as shown in this step. Please, consult details in the last page. / É obrigatório fixar este produto na parede, conforme demonstrado neste passo. Por favor, consulte os detalhes na última página.

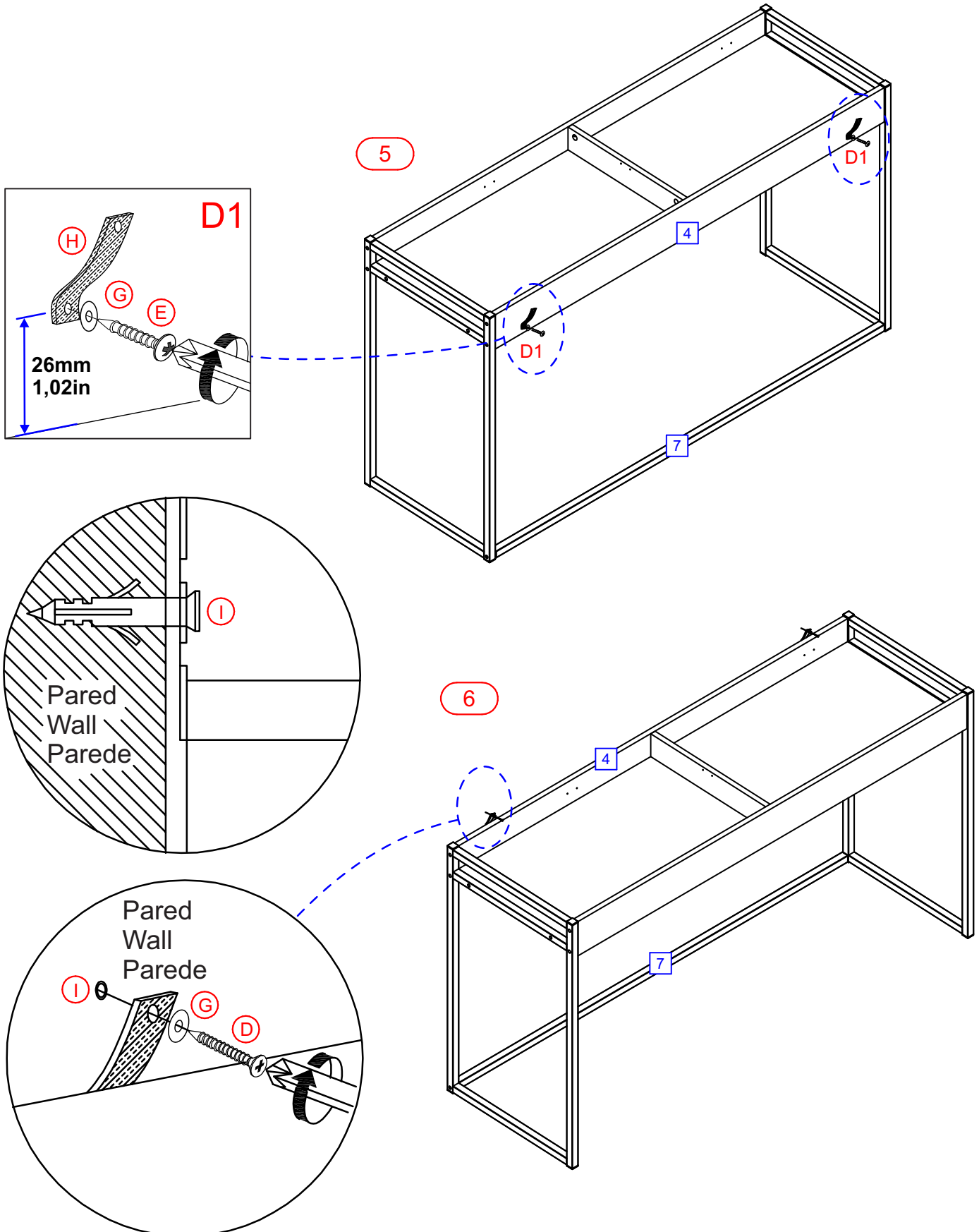

Montaje en pared - Opción 2
Wall Mounting - Option 2
Montagem na parede - Opção 2



Es obligatorio fijar este producto a la pared, como se muestra en este paso. Por favor, consulte los detalles en la última página. / It is obligatory to fix this product to the wall, as shown in this step. Please, consult details in the last page. / É obrigatório fixar este produto na parede, conforme demonstrado neste passo. Por favor, consulte os detalhes na última página.

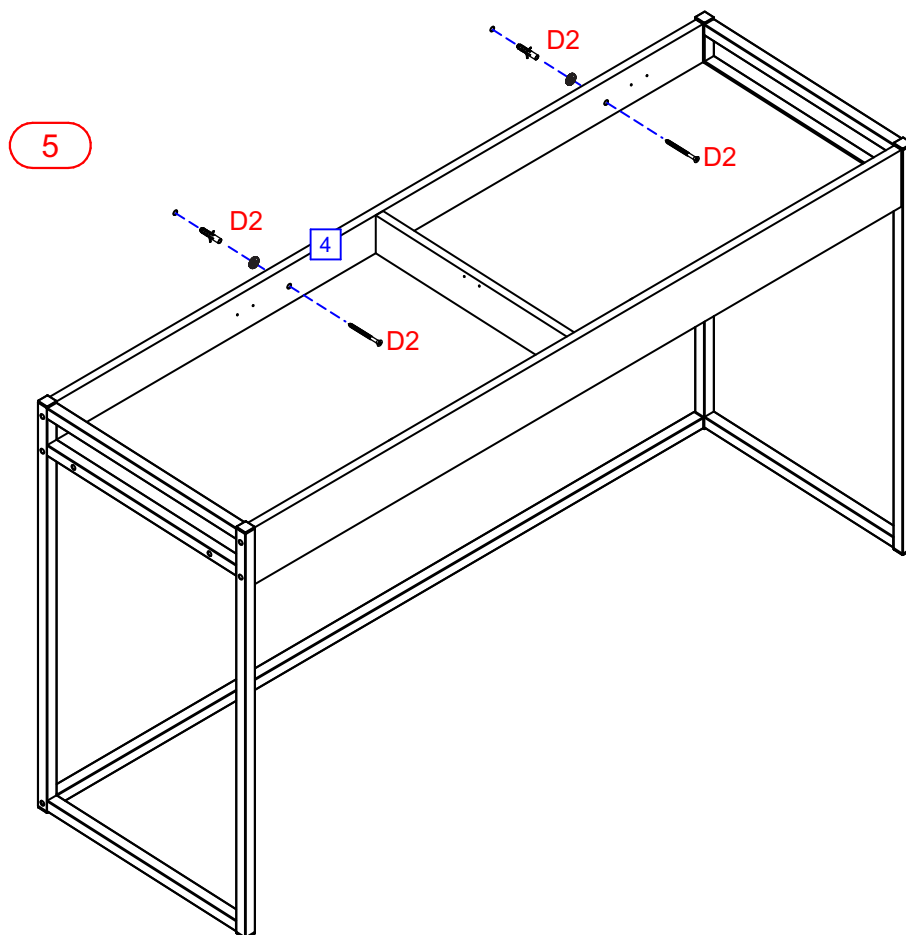
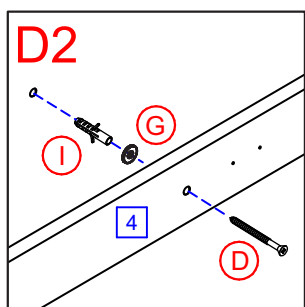

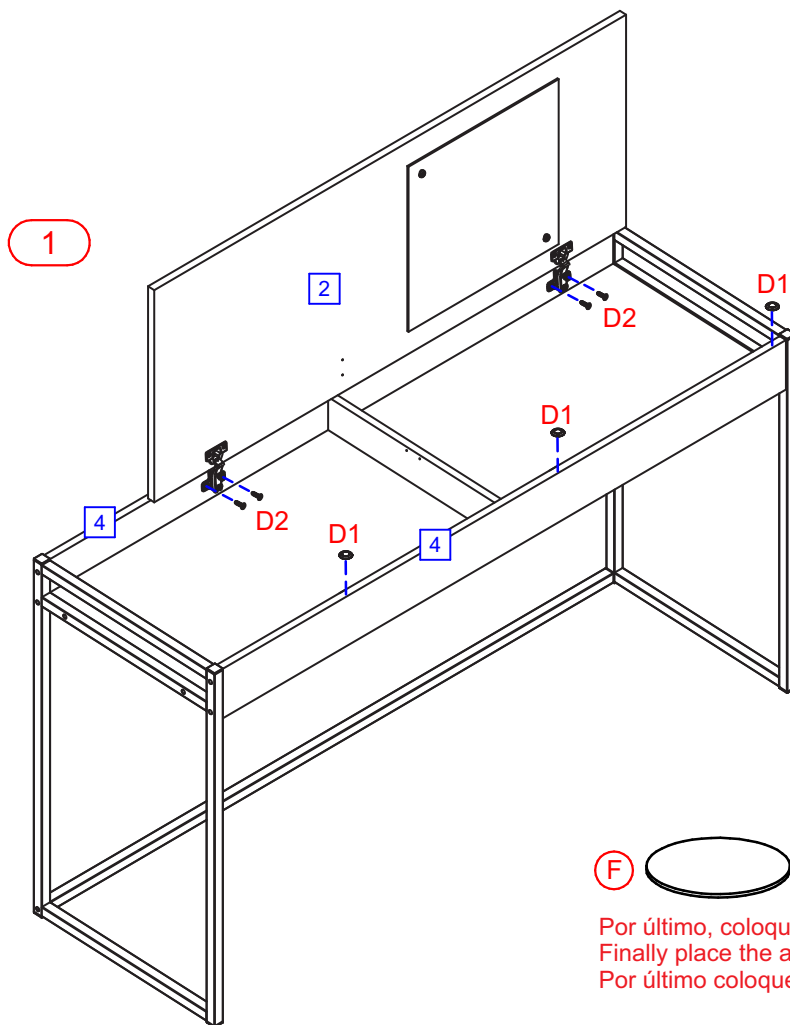
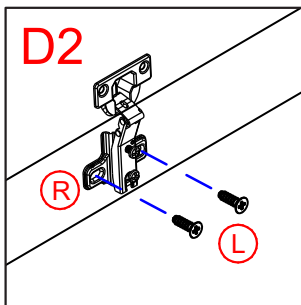
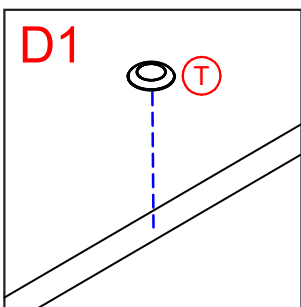
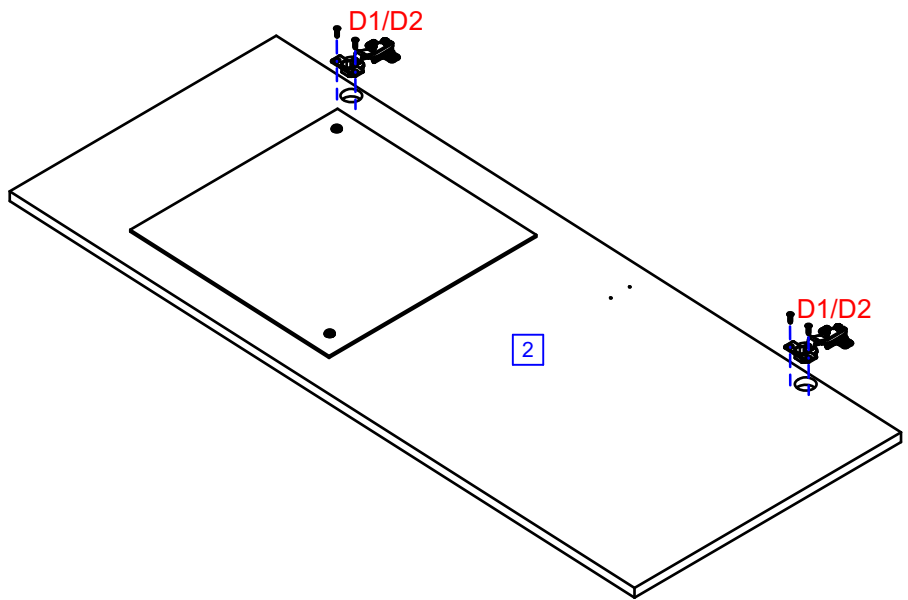
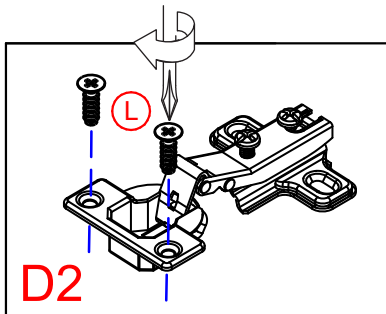
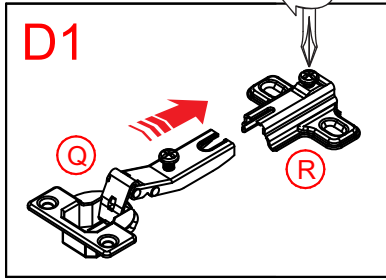

Por último, coloque los accesorios (F).
 Finally place the accessories (F).
 Por último coloque os acessórios (F).

Ajuste de Profundidad
 Depth Adjustment
 Ajuste de la profundidad

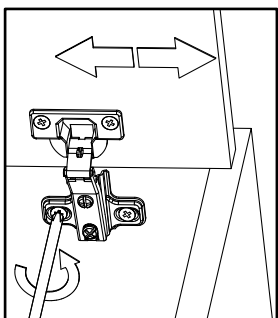

Ajuste Interno
 Internal Adjustment
 Ajuste Interno

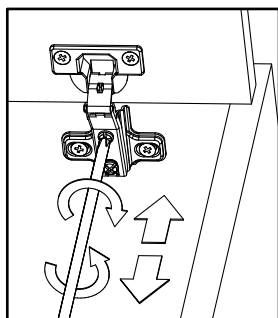

Ajuste de Altura
 Height Adjustment
 Ajuste del alto

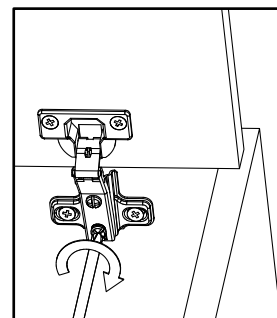
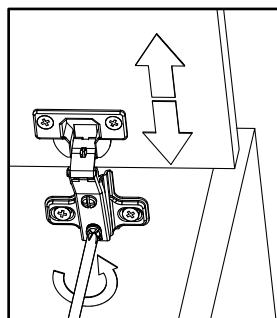

Atención
Attention
Atenção

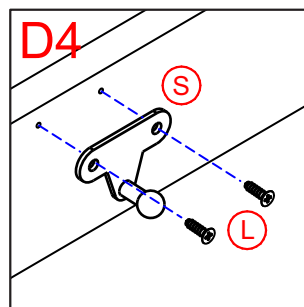
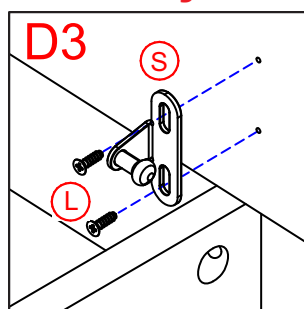

2

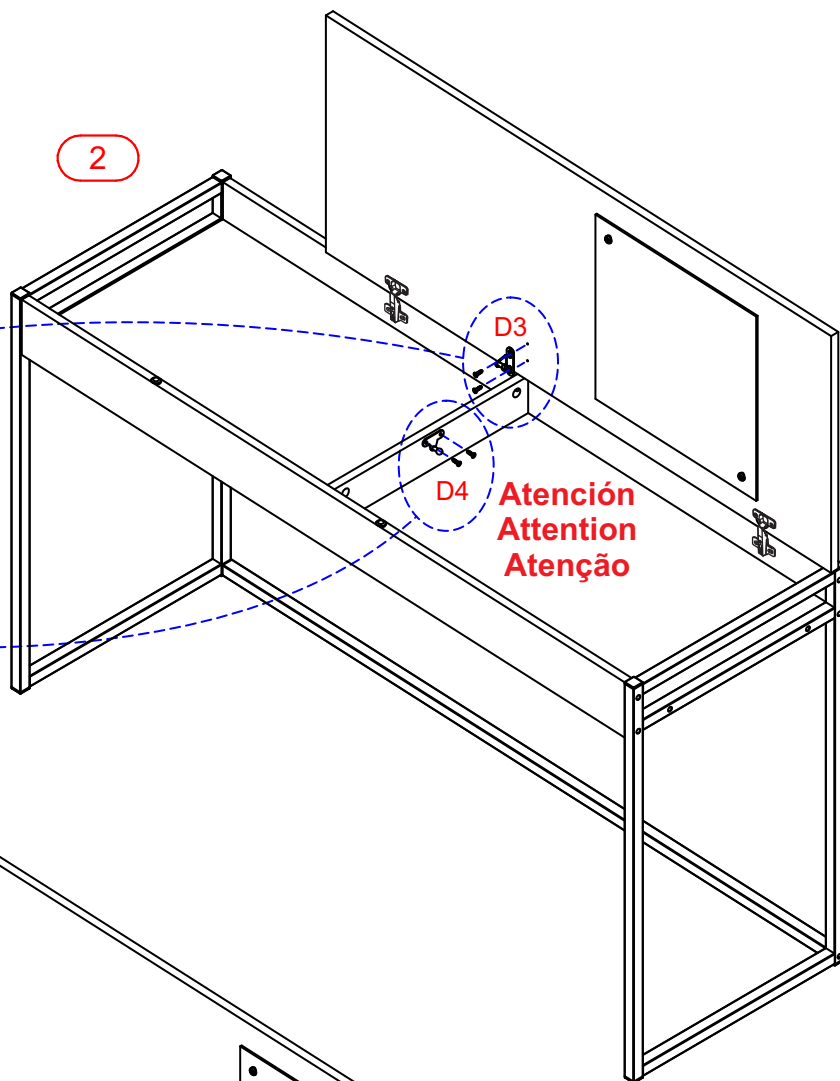

3

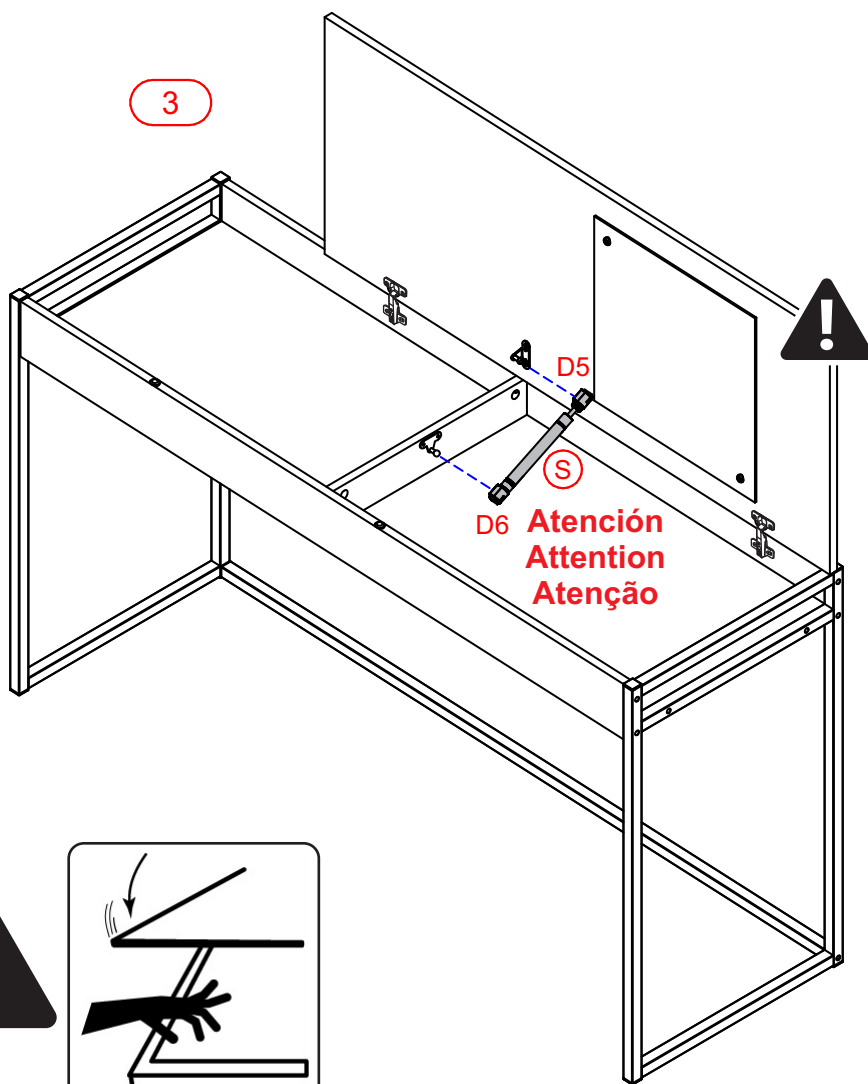

Atención
Attention
Atenção

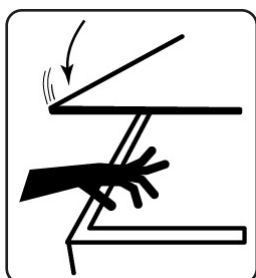
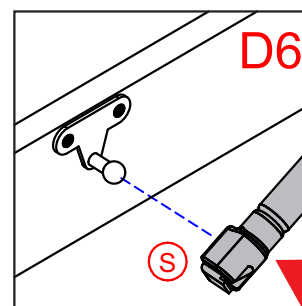
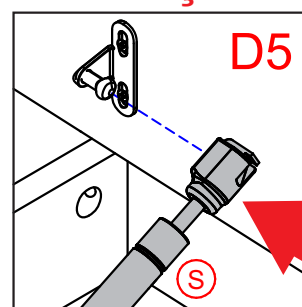

!!!ATENCIÓN!!! Al cerrar la puerta, mantenga las manos y los dedos alejados, ya que existe el riesgo de aplastamiento.
!!!CAUTION!!! When closing the door, keep your hands and fingers away as there is a risk of crushing.
!!!CUIDADO!!! No fechamento da porta, mantenha as mãos e os dedos afastados, pois há risco de esmagamento.

Guía de Montaje/Fijación a la pared - Mounting Guide/Wall Fixings - Guia de Montagem/Fixações na Parede



1. Al taladrar en las paredes, compruebe siempre que no haya cables, tuberías ocultos, etc.
1. When drilling into walls always check that there are no hidden wires, pipes, etc.
1. Atenção: Na furação em paredes, sempre verifique se não existem fios, tubos escondidos, etc.
2. Asegúrese de que los tornillos y bujes de la pared utilizados sean adecuados para soportar su producto. En caso de duda, consulte a un profesional cualificado.
2. Make sure that the screws and wall plugs being used are suitable for supporting your product. Consult a qualified professional if you are unsure.
2. Certifique-se de que os parafusos e buchas utilizados são adequados para suportar o seu produto. Em caso de dúvida, consulte um profissional qualificado.



1. Asegúrese de usar el taladro correcto para que coincida con el buje de la pared y el tamaño del taladro.
1. Ensure to use the recommended drill bit to match the wall plug and hole size.
1. Certifique-se de utilizar a broca correta para combinar com a bucha de parede e o tamanho da furação.
2. Asegúrese de taladrar el agujero horizontalmente, no fuerce la taladradora ni agrande el agujero.
2. Ensure to drill the hole horizontally, do not force the drill or enlarge the hole.
2. Certifique-se de fazer o furo na horizontal, não force ou aumente o diámetro do furo.
3. Asegúrese de que los bujes de la pared estén bien asentados y apretados en los orificios.
3. Ensure wall plugs are well fitted and are a tight fit in the drilled hole.
3. Certifique-se de que as buchas de parede estão bem encaixadas e apertadas nas furações.



- Buje Plastica 6mm/0,24in (suministradas) / 6mm/0,24in Plastic Wall Plug (supplied) / Bucha Plástica 6mm/0,24in (fornecidas)**
1. Estos bujes de pared de plástico sólo son adecuados para su uso en paredes de mampostería.
 1. These types of wall plugs are only suitable for use in masonry walls.
 1. Estas buchas plásticas de parede são adequadas somente para uso em paredes de alvenaria.
 2. La falla del producto debido al uso de fijaciones incorrectas es responsabilidad del instalador.
 2. Failure of the product due to using incorrect fixings is the responsibility of the installer.
 2. A falha do produto devido à utilização de fixações incorretas é de responsabilidade do instalador.

Tipos de Pared y Fijaciones / Wall Types and Fixings / Tipos de Parede e Fixações

* En la siguiente tabla se muestran ejemplos de modelos de bujes de pared y su aplicación según el material de la pared. **ATENCIÓN**, ya que todas las cargas soportadas son válidas siempre que la instalación cumpla con las especificaciones ideales. En caso de duda, consulte a un profesional cualificado para la correcta instalación.

* In the table below, examples of models of wall plugs and their application according to the material of the wall. **ATTENTION**, as all supported loads are valid as long as the installation complies with the ideal specifications. In case of doubt, consult a qualified professional for the correct installation.

* Na tabela abaixo, exemplos de modelos de buchas de parede e sua aplicação conforme o material da parede. **ATENÇÃO**, pois todas as cargas suportadas são válidas desde que a instalação respeite as indicações ideais. Em caso de dúvidas, consulte um profissional qualificado para a correta instalação.

Modelos de Bujes de Pared / Modelos de Buchas / Models of Wall Plugs

Tipos de Pared Wall Types Tipos de Parede											
Hormigón Concrete Concreto	✓	✓	✓								✓
Bloque de Hormigón Concrete Block Bloco de Concreto	✓	✓	✓	✓	✓						
Ladrillo Hueco Hollow Brick Tijolo Oco		✓	✓	✓	✓						
Ladrillo Macizo Solid Brick Tijolo Maciço	✓	✓	✓								✓
Paneles de yeso (Drywall) Drywall Painel de Drywall			✓		✓	✓	✓	✓	✓	✓	